

## Modifying Nissan R200 and R200B Differential for use with Good Parts Installation Kit

- 1) Stamp or paint locating marks on input shaft, nut and front flange. Remove flange using puller. Machine according to illustration.

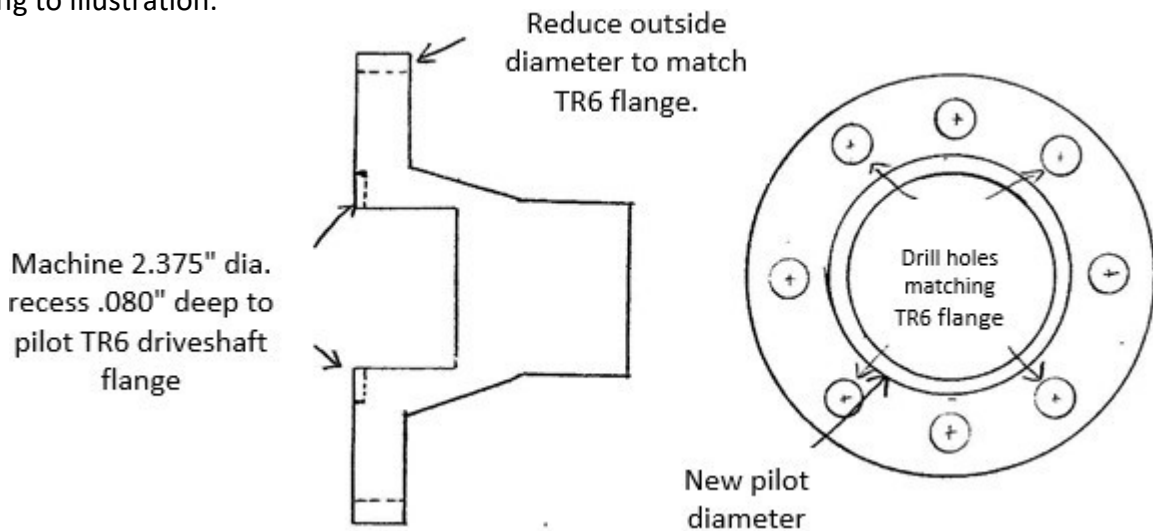

- 2) Reinstall front flange with locating marks aligned, tighten nut until it stops. Torque nut until all locating marks are aligned. **Do Not** torque nut past locating mark.
- 3) Remove mounting stud(s) from rear cover and chamfer holes to clear tapered bolt head where it protrudes through mounting bracket. R200 diffs have 2 studs, R200B have 1 stud. Do not strip aluminum threads.



- 4) Grind away front half of protrusion on top of case.

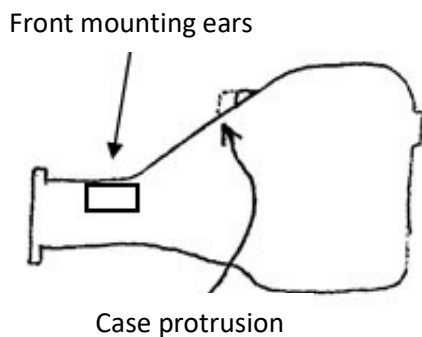

- 5) **R200 Only:** Remove rubber/metal isolators from front mounting ears. **DO NOT** remove R200B isolators.